

TECHNICAL PARAMETERS

| Winch type | Nominal Pull | Nominal Speed | Light Line Speed | Ropes | | Length of Rope | | Warping End Nominal Pull | Minimum Output of Electric Motor |
|------------|--------------|---------------|------------------|---------------------|----------------------|----------------|-------------|--------------------------|----------------------------------|
| | | | | Diam. of Steel Rope | Diam. of Synth. Rope | Steel Rope | Synth. Rope | | |
| | [kN] | [m/min] | [m/min] | [mm] | [mm] | [m] | [m] | [kN] | [kW] |
| C6 | 60 | 15 | 30 | 18 | 48 | 180 | 200 | 50 | 18 |
| C8 | 80 | | | 22 | 56 | | | | |
| C10 | 100 | | | 24 | 60 | | | | |
| C12 | 125 | | | 26 | 64 | | | | |
| C16 | 160 | | | 32 | 76 | 250 | | 125 | 45 |
| C20 | 200 | | | 36 | 88 | | | | |
| C25 | 250 | | | 40 | 96 | | | | |
| C30 | 300 | | | 44 | 100 | | | | |

Other sizes and parameters on request.

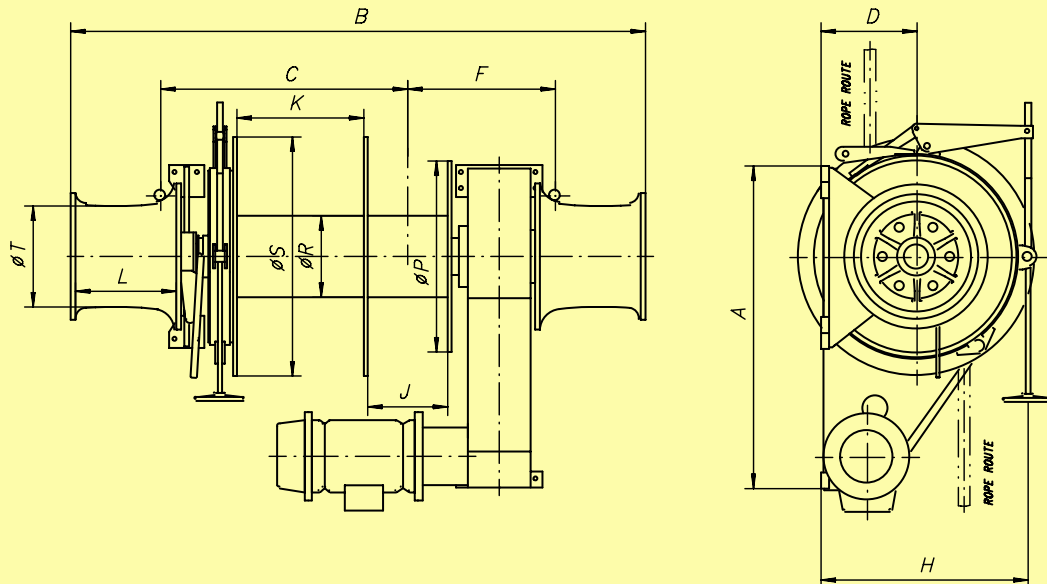

Dimensions and Weight

| Winch type | Dimensions [mm] | | | | | | | | | | | | | Weight with motor [kg] |
|-------------------|-----------------|------|------|-----|------|------|------|---|-----|------|-----|------|-----|------------------------|
| | A | B | C | D | F | H | J | K | L | Ø P | Ø R | Ø S | Ø T | |
| Steel rope | | | | | | | | | | | | | | |
| C6 | 1800 | 2295 | 785 | 500 | 860 | 960 | 895 | - | 360 | 600 | 355 | 850 | 360 | 2550 |
| C8 | 1800 | 2680 | 900 | 500 | 980 | 960 | 1100 | - | 450 | 600 | 355 | 850 | 450 | 2650 |
| C10 | 2020 | 2975 | 1035 | 600 | 1135 | 1150 | 1230 | - | 450 | 700 | 406 | 1100 | 450 | 3300 |
| C12 | 2020 | 2975 | 1035 | 600 | 1135 | 1150 | 1230 | - | 450 | 750 | 457 | 1100 | 450 | 3400 |
| C16 | 2010 | 3465 | 1140 | 600 | 1325 | 1150 | 1420 | - | 560 | 1100 | 520 | 1100 | 560 | 4400 |
| C20 | 1850 | 3545 | 1175 | 800 | 1390 | 1150 | 1320 | - | 630 | 1100 | 580 | 1100 | 630 | 4600 |
| C25 | 2100 | 3855 | 1340 | 800 | 1385 | 1300 | 1400 | - | 630 | 1100 | 640 | 1100 | 630 | 6200 |
| C30 | 2320 | 3900 | 1380 | 800 | 1450 | 1300 | 1400 | - | 710 | 1200 | 710 | 1200 | 710 | 8100 |

| Synthetic rope | Dimensions [mm] | | | | | | | | | | | | | Weight with motor [kg] |
|----------------|-----------------|------|------|-----|------|------|-----|------|-----|------|-----|------|-----|------------------------|
| | A | B | C | D | F | H | J | K | L | Ø P | Ø R | Ø S | Ø T | |
| C6 | 1800 | 2295 | 1030 | 500 | 615 | 960 | 400 | 480 | 360 | 850 | 355 | 1200 | 360 | 2650 |
| C8 | 1800 | 2680 | 1240 | 500 | 640 | 960 | 420 | 675 | 450 | 850 | 355 | 1200 | 450 | 2750 |
| C10 | 2020 | 3210 | 1475 | 600 | 790 | 1150 | 500 | 725 | 560 | 1050 | 406 | 1400 | 560 | 3900 |
| C12 | 2020 | 3210 | 1475 | 600 | 790 | 1150 | 500 | 725 | 560 | 1050 | 406 | 1400 | 560 | 4000 |
| C16 | 2010 | 3465 | 1525 | 600 | 815 | 1150 | 400 | 900 | 560 | 1250 | 457 | 1490 | 560 | 5000 |
| C20 | 1850 | 3645 | 1635 | 800 | 880 | 1150 | 400 | 1000 | 630 | 1490 | 406 | 1490 | 630 | 4800 |
| C25 | 2100 | 3855 | 1740 | 800 | 985 | 1300 | 500 | 1000 | 630 | 1650 | 580 | 1650 | 630 | 6500 |
| C30 | 2320 | 4200 | 1600 | 800 | 1050 | 1300 | 600 | 1200 | 710 | 1800 | 580 | 1800 | 710 | 8800 |